

AIRMIX®

AVX & ATX



AUTOMATIC AIRMIX® SPRAY GUNS

- High transfer efficiency (up to **86%***)
- Excellent atomization
- Modular design

* ± 2% according to (EN 13966-1)



Experts in Finishing and Dispensing Solutions

www.kremlinrexson-sames.com/en/us

AIRMIX®

AVX & ATX

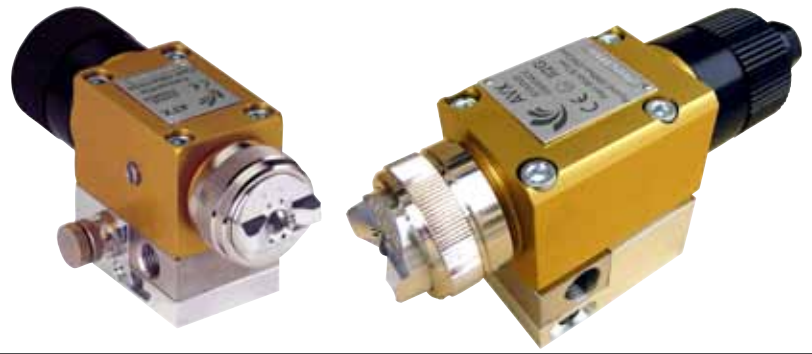

TECHNICAL DATA

	AIRMIX® AVX	AIRMIX® ATX
Maximum fluid operating pressure	2900 psi / (200 bar)	
Atomization air pressure	10.1 - 43 psi / (0.7 > 3 bar)	
Minimum trigger pressure	43 psi / (3 bar)	
Fluid flow rate	Based on tip selection	
ATX weight gun (side input)	-	w/o base 26.4 oz / (750 g) with base 37.4 oz / (1060 g)
AVX weight gun (side and rear input)	8.5 oz side input / 16.9 oz rear input (240 g side input / 480 g rear input)	
Maximum operating temperature	122°F / (50°C)	
Seat construction	Stainless steel (polyacetal optional)	
Wetted parts	Stainless steel, treated stainless steel, PTFE or GT seal	

AIRMIX® TECHNOLOGY

AIRMIX® technology was invented by KREMLIN REXSON in 1975 to reduce paint consumption, reduce cost of ownership, increase productivity, improve working conditions and preserve the environment.

Continuously improved over the past 35 years, AIRMIX® is the most efficient non-electrostatic spray technology, providing up to 86% transfer efficiency.

As a result, most automatic machine manufacturers using medium fluid pressure atomization recommend KREMLIN REXSON's AIRMIX® automatic guns because they are reliable, deliver outstanding finish quality and their simple construction minimizes the cost of servicing and down time.

MATERIAL APPLICATIONS

Stains, 2K material, P.U, epoxy, gelcoat, U.V. coating, solvent and waterbased paints.

RECOMMENDED MARKETS



KITCHEN AND BATHROOM



DRUMS



RENEWABLE ENERGIES



EXTERIOR JOINERY

CUSTOMER BENEFITS

Simple construction with a limited number of parts ←

High reliability ↓

Low cost of ownership ↓

Compact and light weight ←

Easy servicing and cleaning ←

SEQUENTIAL OPENING

Dual springs mounted outside the fluid passage allows airflow prior to material flow

RULON OR GT SEAL CARTRIDGE

- Rulon seal available on AVX gun
- Extended lifetime with most coatings
- GT seal available on ATX gun
- Recommended for U.V and abrasive coatings

HIGH EFFICIENCY AIRCAPS AND SPRAY TIPS

- VX24 (adjustable spray) or VX124 (fixed spray) and a large offering of fine finish and Xtra™ fine finish spray tips
- Extremely accurate film build consistency

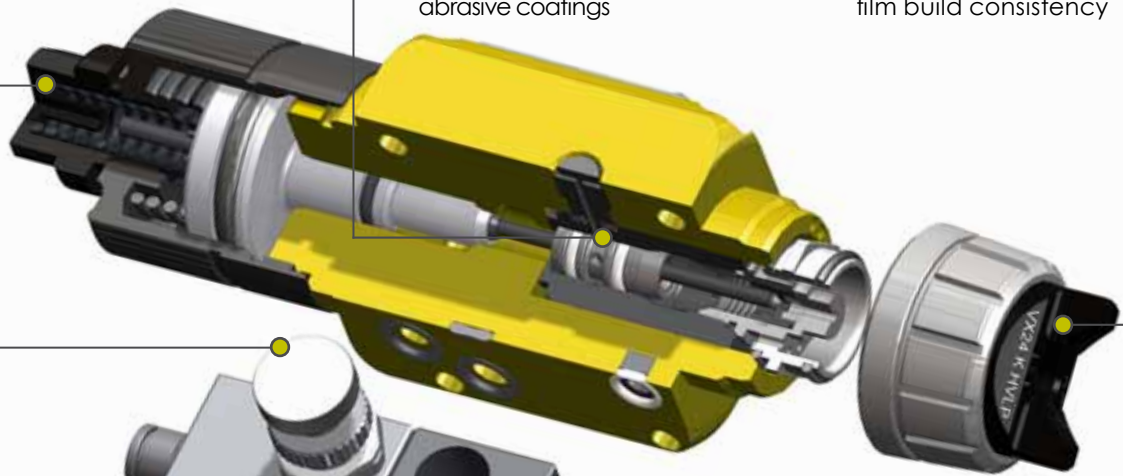

MODULAR DESIGN

- Easy assembling and disassembling (4 bolts)
- Easy servicing

FAN AIR REMOTE CONTROL

Optional

STAINLESS STEEL PASSAGES

Compatible with a large range of products (solvent base & waterborne)

CIRCULATION IN THE GUN

Quicker and better flushing with a limited volume if solvent sprayed into the machine or spray booth



CIRCULATION IN THE BASE

Less pressure loss in circulation systems



EXPERTS IN FINISHING AND DISPENSING SOLUTIONS FOR ALL MARKETS WORLDWIDE

WHERE TO FIND US ?

WWW.KREMLIN-REXSON.COM/EN/USA



KREMLIN REXSON, creator of AIRMIX[®], FLOWMAX[®] and CYCLOMIX[™] technologies, offers a wide range of pumps and equipment for the protection of materials and application of paints, sealants and adhesives.



www.kremlinrexson-sames.com/en/usa/

EXEL North America, Inc.
North American Headquarters
45001 5 Mile Road
Plymouth, MI 48170
Toll Free: (800) 573-5554
Phone: (734) 979-0100
Fax: (734) 927-0064

EXEL North America, Inc.
Canadian Branch
931 Progress Ave., Unit 7
Scarborough, Ontario M1G 3V5
Toll Free: (800) 450-0655
Phone: (416) 431-5017
Fax: (416) 431-9171

EXEL-NA, S.A. de C.V.
Acceso III N°16A Int 15A
Conjunto Quadrum
Parque Industrial Benito Juárez
Santiago de Querétaro, Qro.
México, C.P. 76120
+52 (442) 209-5027 /161-2595 Ext 170 Oficina
+52 (81) 1811-0955 Nextel ID: 92*898188*2