

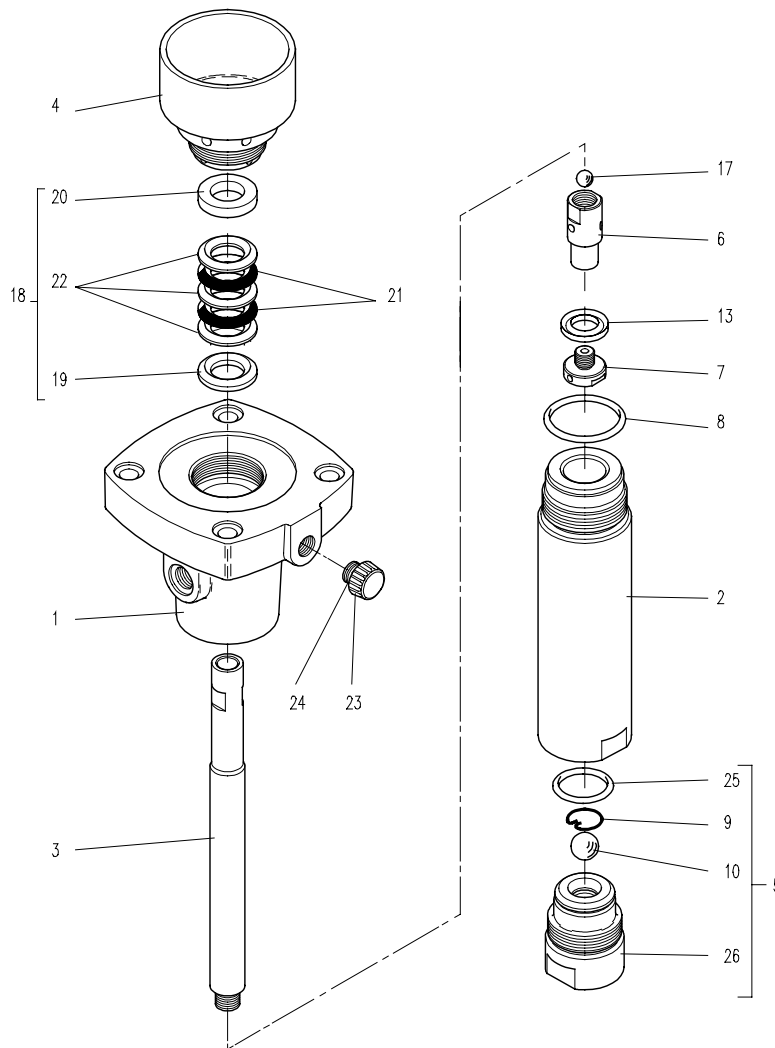

Doc. 573.032.050 Date/Datum/Fecha : 10/06/02 Annule/Cancela/ Ersetzt/Anula :	Modif. /Änderung :	Pièces de rechange Spare parts list Ersatzteilliste Piezas de repuesto
--	---------------------------	---

HYDRAULIQUE, modèle 25 (gar- niture mobile avec joint GT)	FLUID SECTION, model 25 (mo- bile GT packing with GT seal)	#
HYDRAULIKTEIL, Modell 25 (mobile Pakcung mit GT- Dichtungsring)	HIDRÁULICA, tipo 25 (guarnición móvil con junta GT)	144.950.000



Hydraulique avec joint GT (à partir de la pompe N° série : 77 379)
Fluid section with GT seal (from pump serie N°: 77 379)
Hydraulikteil mit GT-Dichtungsring (ab Pumpe N° 77 379)
Hidráulica con junta GT (a partir de la bomba con el N° de serie : 77 379)

Ind	#	Désignation	Description	Bezeichnung	Denominación	Qté
1	044.950.001	Bride supérieure	Upper flange	Oberer Flansch	Brida superior	1
* 2	044.950.002	Cylindre	Cylinder	Materialzylinder	Cilindro	1
* 3	044.950.003	Piston	Piston	Materialkolben	Pistón	1
4	044.950.004	Cuve presse-garniture	Wetting-cup	Spülmitteltasse	Cubeta prensa-guarnición	1
5	044.950.010	Clapet d'aspiration as-semblé	Suction valve assembly	Ansaugventil, komplett	Válvula aspiración completa	1
9	044.550.029	▪ Jonc	▪ Rush	▪ Sicherungsring	▪ Anillo de retención bola	1
10	907.414.242	▪ Bille Ø 16, inox 440C	▪ Ball Ø 16 (5/8 "), stainless steel 440C	▪ Kugel, Ø 16, Edelstahl 440C	▪ Bola Ø 16, inox 440C	1
25	050.040.318	▪ Joint torique	▪ O Ring	▪ O-Ring	▪ Junta O Ring	1
26	NCS / NSS	▪ Corps de clapet	▪ Valve body	▪ Saugventil	▪ Cuerpo de válvula	1
6	044.950.215	Clapet de refoulement	Exhaust valve	Druckventil	Válvula de expulsión	1
7	044.950.007	Presse-garniture mobile	Wetting-cup, mobile	Spülmitteltasse, mobil	Prensa-guarnición móvil	1
8	050.040.317	Joint torique	O Ring	O-Ring	Junta O Ring	1
13	909.150.214	Joint GT inférieur (garniture mobile)	Seal GT lower (mobile packing)	Unterer Gt-Dichtungsring (mobile Packung)	Junta GT inferior (guarnición móvil)	1
17	907.414.223	Bille Ø 9,52, inox 440C	Ball Ø 9,52 (3/8 "), stainless steel 440C	Kugel, Ø 9,52, Edelstahl 440C	Bola Ø 9,52, inox 440C	1
18	-	Garniture supérieure	Upper packing	Obere Packung	Guarnición superior	1
19	044.790.011	▪ Bague male, polyacetal	▪ Male ring, polyacetale	▪ O-Ring für AG, aus Polyacetal	▪ Anillo macho, poliacetale	1
20	044.791.012	▪ Bague femelle, inox	▪ Female ring, inox	▪ O-Ring für IG, aus Edelstahl	▪ Anillo hembra, inox	1
21	909.050.915	▪ Joint chevron, polyfluid	▪ Chevron seal, polyfluid	▪ Packungsring aus Polyfluid	▪ Junta chevrón, polifluida	2
22	044.790.013	▪ Joint chevron, PTFEG	▪ Chevron seal, PTFEG	▪ Packungsring aus PTFEG	▪ Junta chevrón, PTFEG	3
23	144.950.012	Bouchon de vidange	Drain plug	Ablaßschraube	Tapón de vaciado	1
24	109.020.401	▪ Joint plat (x 5)	▪ Flat seal (x 5)	▪ Flachdichtung (5 Stück)	▪ Junta plana (bolsa de 5)	1

Ind	#	Désignation	Description	Bezeichnung	Denominación	Qté
		Accessoires	Accessories	Zubehör	Accesorios	
31	044.950.008	Clé pour cuve presse-garniture	Wrench for wetting-cup	Schlüssel für Spülmittel-tasse	Llave para prensaestopa	1
-	149.990.020	Flacon de lubrifiant T (1/4 de litre)	T lubricant (1/4 liter)	Spülmittel T (1/4 Ltr)	Botella de lubricante T (1/4 de litro)	1

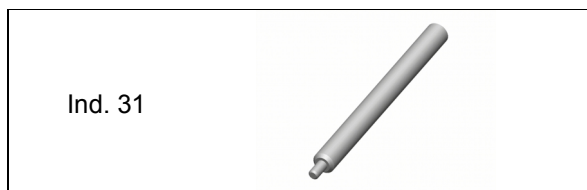

Ind	#	Désignation	Description	Bezeichnung	Denominación	Qté
*	144.950.091	Pochette de joints (ind. 8, 9, 10, 13, 17, 19, 21(x2), 22(x3), 24, 25)	Package of seals (ind. 8, 9, 10, 13, 17, 19, 21(x2), 22(x3), 24, 25)	Dichtungssatz für Hydraulikteil (beinhaltet Pos. 8, 9, 10, 13, 17, 19, 21(x2), 22(x3), 24, 25)	Bolsa de juntas (ind. 8, 9, 10, 13, 17, 19, 21(x2), 22(x3), 24, 25)	1
*	144.950.096	Pochette de maintenance (ind. 5, 6 + pochette de joints)	Servicing kit (ind. 5, 6 + package of seals)	Servicekit für Hydraulikteil (beinhaltet Pos. 5, 6 und den Dichtungssatz)	Bolsa de mantenimiento (ind. 5, 6 + bolsa de juntas)	1

* Pièces de maintenance préconisées tenues en stock.
* Preceding the index number denotes a suggested spare part.
* Bezeichnete Teile sind empfohlene Ersatzteile.
* Piezas de mantenimiento preventivo a tener en stock.

N C S : Non commercialisé seul.
N S S : Denotes parts are not serviceable separately.
N S S : bezeichnete Teile gibt es nicht einzeln, sondern nur komplett.
N C S : no suministrado por separado.

		EN OPTION :	OPTIONAL :	OPTION :	OPCION :	
Ind	#	Désignation	Description	Bezeichnung	Denominación	Qté
10	907.414.142	Bille Ø 16 inox 316	Ball Ø 16, 316 (stainless steel)	Kugel (Edelstahl), Ø 16, 316	Bola Ø 16, inox, 316	1
17	907.414.123	Bille Ø 9,52 inox 316	Ball Ø 9,52, 316 (stainless steel)	Kugel (Edelstahl), Ø 9,52, 316	Bola Ø 9,52, inox, 316	1
18	144.950.100	Cartouche supérieure avec joint GT	Upper packing with GT seal	Obere Packung, GT - Dichtung	Cartucho superior (GT)	1
22	909.051.103	Joint chevron, PE	Chevron seal, PE	Packungsring, PE	Junta chevrón, PE	3

OPTION : Pièces spécifiques pour garniture mobile avec joints chevrons	OPTION : specific parts for mobil packing with chevron seals
OPTION : Spezielle Teile für mobile Packung mit Packungsringen	OPCIÓN : partes específicas para guarnición móvil con juntas de chevrón

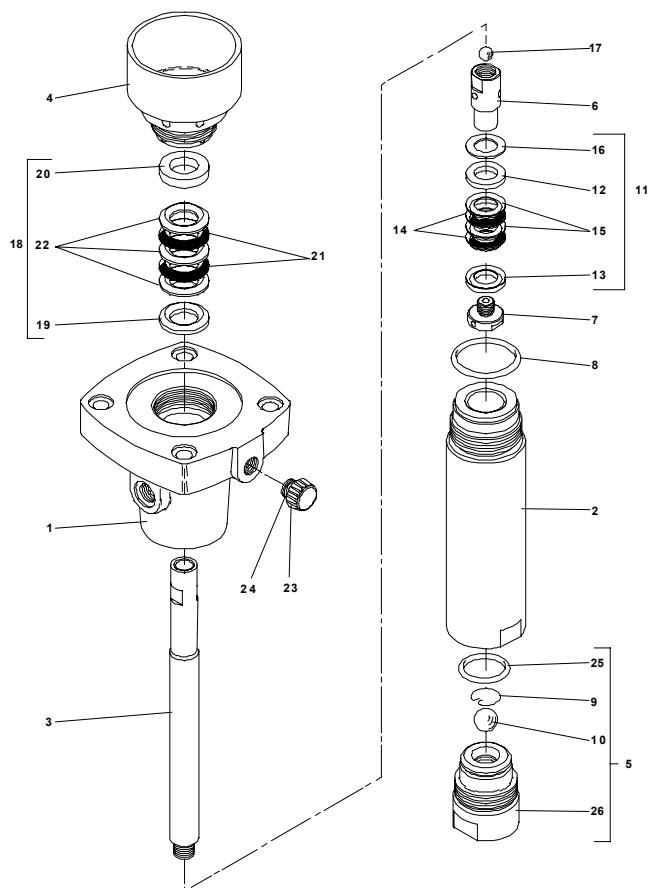

Ind	#	Désignation	Description	Bezeichnung	Denominación	Qté
6	044.950.011	Clapet de refoulement	Exhaust valve	Druckventil	Válvula de expulsión	1
12	044.790.006	Rondelle male, polyacétal	Male washer, polyacetale	Scheibe, AG, aus Polyacetal	Arandela macho, poliacetale	1
13	044.790.007	Rondelle femelle, polyacetal	Female washer, polyacetale	Scheibe, IG, aus Polyacetal	Arandela hembra, poliacetale	1
14	044.790.008	Joint chevron, PTFEG	Chevron seal, PTFEG	Packungsring, PTFEG	Junta chevrón, PTFEG	2
15	909.051.104	Joint chevron, PE	Chevron seal, PE	Packungsring, PE	Junta chevrón, PE	2
16	044.790.015	Rondelle de calage, inox (facultative)	Set ring, stainless steel (optional)	Stützscheibe, Edelstahl (fakultativ)	Arandela, inox (facultativa)	1
-	144.950.090	Pochette de joints (ind. 8, 9, 10, 12, 13, 14, 15, 16, 17, 19, 21, 22, 24, 25)	Package of seals (ind. 8, 9, 10, 12, 13, 14, 15, 16, 17, 19, 21, 22, 24, 25)	Dichtungssatz für Hydraulikteil (beinhaltet Pos. 8, 9, 10, 12, 13, 14, 15, 16, 17, 19, 21, 22, 24, 25)	Bolsa de juntas (ind. 8, 9, 10, 12, 13, 14, 15, 16, 17, 19, 21, 22, 24, 25)	1
-	144.950.095	Pochette de maintenance (ind. 5, 6 + pochette de joints)	Servicing kit (ind. 5, 6 + package of seals)	Servicekit für Hydraulikteil (beinhaltet Pos. 5, 6 und den Dichtungssatz)	Bolsa de mantenimiento (ind. 5, 6 + bolsa de juntas)	1