

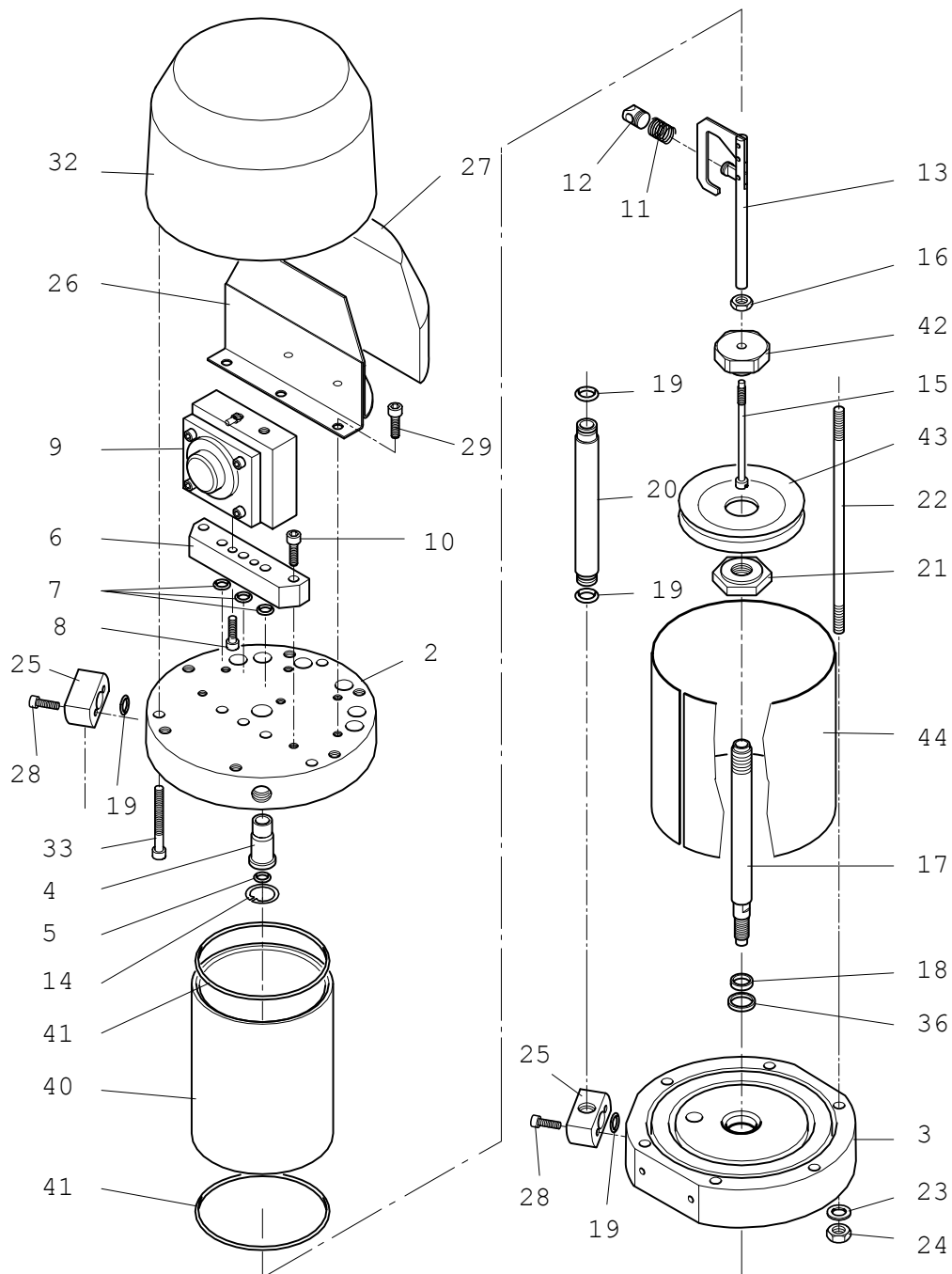

Doc. 573.045.050 Date/Datum/Fecha : 20/05/08 Annule/Cancel/ Ersetzt/Anula : 10/06/02	Modif. /Änderung : Pochette / Pack / Satz / Bolsa # 146.270.991 (Ind. 36)	Pièces de rechange Spare parts list Ersatzteilliste Piezas de repuesto
------------------------------------------------------------------------------------------------------	-------------------------------------------------------------------------------------	-------------------------------------------------------------------------------------------------------------

MOTEUR A AIR, modèle 1000 - 4 & 1000 - 4 T	AIR MOTOR, model 1000 - 4 & 1000 - 4 T
LUFTMOTOR, Modell 1000 - 4 & 1000 - 4 T	MOTOR DE AIRE, tipo 1000 - 4 & 1000 - 4 T



MOTEUR A AIR, modèle 1000-4	AIR MOTOR, model 1000-4	# 146.275.000
LUFTMOTOR, Modell 1000-4	MOTOR DE AIRE, tipo 1000-4	

Ind	#	Désignation	Description	Bezeichnung	Denominación	Qté
		Pièces spécifiques au moteur 1000-4	Specific parts to the air motor, model 1000-4	Spezielle Teile für Luftmotor 1000-4	Partes específicas a las partes, tipo 1000-4	
2	046.270.901	Fond supérieur	Upper flange	Oberer Flansch	Fondo superior	1
6	046.230.005	Embase bloc inverseur	Base, reversing-block	Grundplatte, Umsteuerblock	Base bloque inversor	1
20	046.144.901	Tube d'alimentation	Tube, connecting	Versorgungsrohr	Tubo de alimentación	1
25	046.270.903	Collecteur	Collector	Verbindungsflansch	Colector	2
26	046.270.904	Support (silencieux)	Support (silencer)	Halterung (Schalldämpfer)	Soporte (silenciador)	1
27	046.270.905	Silencieux (mousse)	Silencer	Schalldämpfer (Schaumstoff)	Silenciador	1
28	933.151.443	Vis CHc M 6 x 35	Screw, CHc M 6 x 35	Schraube CHc AG 6 x35	Tornillo, CHc M 6 x 35	4
29	933.151.122	Vis CHc M 6 x 8	Screw, CHc M 6 x 8	Schraube CHc AG 6 x 8	Tornillo, CHc M 6 x 8	3

		Pièces communes aux moteurs 1000-4 et 1000-4T (turbo)	Common parts to the air motors, model 1000-4 and 1000-4T (turbo)	Gleiche Teile in Motoren 1000-4 und 1000-4T (turbo)	Partes comunes de los motores, tipo 1000-4 y 1000-4T (turbo)	
3	146.270.902	Fond inférieur	Lower flange	Unterer Flansch	Fondo inferior	1
4	044.570.106	Bague de guidage	Guide ring	Führungsring	Anillo guía	1
5	144.579.923	Bague R 8 bis (pochette de 10)	Ring, R 8 bis (package of 10)	O-Ring R 8 bis (10er Pack)	Anillo R 8 bis (bolsa de 10)	1
7	109.420.257	Bague O Ring (pochette de 10)	O Ring (package of 10)	O-Ring (10er Pack)	Anillo O Ring (bolsa de 10)	3
8	933.151.277	Vis CHc M 6 x 20	Screw, CHc M 6 x 20	Schraube CHc AG 6 x 20	Tornillo CHc M 6 x 20	2
* 9	044.630.400	Ensemble bloc inverseur (voir Doc. 573.087.040)	Reversing-block (refer to Doc. 573.087.040)	Umsteuerblock komplett (siehe Dok. 573.087.040)	Conjunto bloque inversor (consultar Doc. 573.087.040)	1
10	930.151.446	Vis CHc M 8 x 35	Screw, CHc M 8 x 35	Schraube CHc AG 8 x 35	Tornillo, CHc M 8 x 35	2
11	050.311.232	Ressort	Spring	Feder	Muelle	1
12	044.570.131	Chape femelle	Linkage, female	Verbindungsflansch	Unión hembra	1
13	044.570.900	Fourchette de commande équipée	Control fork assembly	Steuergabel; komplett	Horquilla de mando equipada	1
14	902.202.002	Anneau truarc	Retaining ring	Sicherungsring	Anillo truarc	1
15	046.180.003	Tige de pilotage	Rod, driving	Steuerstange	Eje de mando	1
16	046.144.907	Ecrou	Nut	Mutter	Tuerca	1
17	046.180.007	Tige de piston	Rod, piston	Kolbenstange	Eje de pistón	1
18	046.180.010	Bague de frottement	Seal, ring	Dichtring	Anillo de deslizamiento	1
19	129.400.902	Joint (pochette de 10)	Seal (package of 10)	O-Ring (10er Pack)	Junta (bolsa de 10)	4
21	000.323.716	Contre écrou inférieur	Lower locknut	Untere Kontermutter	Contratuerca inferior	1

Ind	#	Désignation	Description	Bezeichnung	Denominación	Qté
		Pièces communes aux moteurs 1000-4 et 1000-4T (suite)	Common parts to the air motors, model 1000-4 and 1000-4T (follow up)	Gleiche Teile in Motoren 1000-4 und 1000-4T (Fortsetzung)	Partes comunes de los motores, tipo 1000-4 y 1000-4T (a continuación)	
22	044.710.007	Tirant	Tie-rod	Bolzen	Tirante	6
23	963.040.019	Rondelle MN 8	Washer, MN 8	Scheibe MN 8	Arandela MN 8	6
24	953.010.019	Ecrou HM 8	Nut, HM 8	Mutter HM 8	Tuerca HM 8	6
32	046.180.006	Capot moteur	Cover, air motor	Motorhaube	Campana del motor	1
33	933.151.497	Vis CHc M 6 x 40	Screw, CHc M 6 x 40	Schraube CHc AG 6 x 40	Tornillo CHc M 6 x 40	3
36	909.420.291	Joint	Seal	O-Ring	Junta	1
* 40	046.275.001	Cylindre	Cylinder	Zylinder	Cilindro	1
41	100.940.470	Joint de cylindre (x 10)	Seal, cylinder (x 10)	O-Ring, Zylinders (10 St.)	Junta de cilindro (x 10)	2
42	046.144.908	Ecrou de piston	Nut, piston	Kolbenmutter	Tuerca de pistón	1
43	000.323.717	Piston	Piston	Kolben	Pistón	1
44	046.275.002	Virole	Muffler	Muffe	Virola	1
-	901.180.024	Cable de mise à la terre (Lg. 5 m)	Ground (Length 5 m / 16 ft)	Erdungskabel (L : 5m)	Cable de puesta a tierra (5 m de largo)	1
-	963.300.016	Rondelle	Washer	Scheibe	Arandela	1
-	934.011.196	Vis Hc 6 x 16	Screw Hc 6 x 16	Schraube Hc 6 x 16	Tornillo Hc 6 x 16	1

*	146.270.991	Pochette de joints moteur (ind. 5, 7, 11, 18, 19, 36, 41 + pochette de joints inverseur)	Package of seals of the air motor (ind. 5,7,11,18,19, 36, 41 + package of seals of the reversing block)	Dichtungssatz für Motor (Pos. 5, 7,11,18, 19, 36, 41 + Dichtungssatz für Umsteuerblock)	Bolsa de juntas motor (ind. 5, 7, 11, 18, 19, 36, 41 + bolsa de juntas del inversor)	1
*	146.270.995	Pochette de maintenance (ind. 4, 43 + pochette de joints moteur + ind. 3, 5, 7, 8, 13 de l'inverseur)	Servicing kit (ind. 4, 43, + package of seals of the air motor + ind. 3, 5, 7, 8, 13 of the reversing block)	Servicekit (Pos. 4, 43 + Dichtungssatz für Motor + 3, 5, 7, 8, 13 für Umsteuerblock)	Bolsa de mantenimiento (ind. 4, 43 + bolsa de juntas motor + ind. 3, 5, 7, 8, 13 del inversor)	1

* Pièces de maintenance préconisées tenues en stock.

* Preceding the index number denotes a suggested spare part.

* Bezeichnete Teile sind empfohlene Ersatzteile.

* Piezas de mantenimiento preventivo a tener en stock.

MOTEUR A AIR, modèle 1000-4 T (turbo)	AIR MOTOR, model 1000-4 T (turbo)	# 146.276.000
LUFTMOTOR, Modell 1000-4 T (turbo)	MOTOR DE AIRE, tipo 1000-4 T turbo	

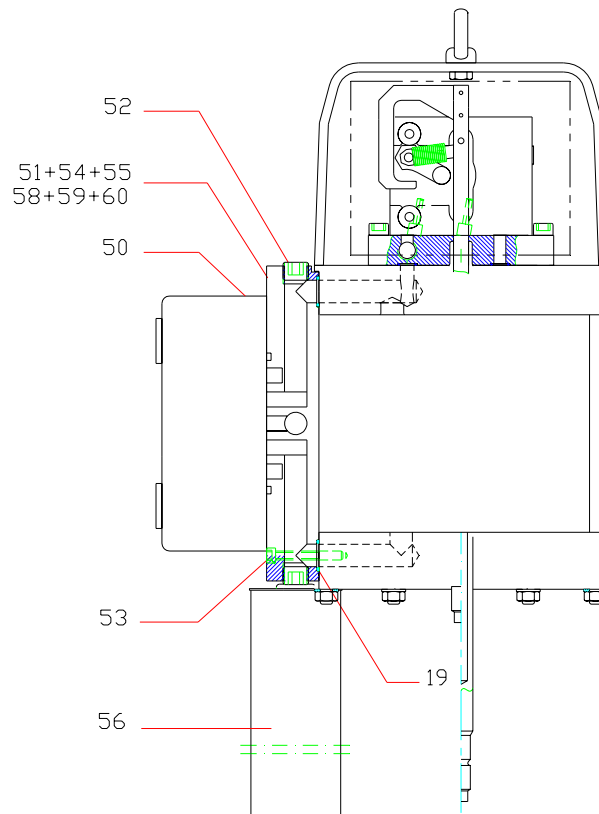

Ind	#	Désignation	Description	Bezeichnung	Denominación	Qté
		Pièces spécifiques au moteur 1000-4 T	Specific parts to the air motor, model 1000-4 T	Spezielle Teile für Luftmotor 1000-4 T	Partes específicas al motor, tipo 1000-4 T	
2	046.271.001	Fond supérieur	Upper flange	Oberer Flansch	Fondo superior	1
6	046.271.002	Embase bloc inverseur	Base, reversing block	Grundplatte, Umsteuerblock	Base, bloque inversor	1
50	903.050.511	Distributeur 5/2 - T3	Distributor, 5/2 - T3	Verteiler 5/2 - T3	Distribuidor, 5/2 - T3	1
51	046.271.004	Embase distributeur	Base, distributor	Grundplatte, Verteiler	Base distribuidor	1
52	906.333.105	Bouchon 3/4 BSP (pour embase)	Plug, 3/4 BSP (for base)	Stopfen 3/4 BSP (für Grundplatte)	Tapón 3/4 BSP (para base)	4
53	930.151.548	Vis CHc M 6 x 50	Screw, CHc M 6 x 50	Schraube CHc AG 6 x 50	Tornillo CHc M 6 x 50	4
54	905.120.905	Raccord coudé M 1/4 BSP - T 4x6	Elbow fitting, M 1/4 BSP - T 4x6	Winkelnippel AG 1/4 BSP - T 4 x 6	Racor acodado M 1/4 BSP - T 4x6	5
55	539.090.115	Tuyau 4x6 (lg. 0,5 m)	Hose, 4x6 (length : 0.5 m / 20")	Schlauch 4x6 (L 0,5 m)	Tubería 4x6 (0,5 m de largo)	1
56	046.250.015	Silencieux	Silencer	Schalldämpfer	Silenciador	1
58	050.102.215	Raccord MM 3/4 BSP	Fitting, double male, 3/4 BSP	Nippel AG 3/4 BSP	Racor, MM 3/4 BSP	1
59	904.123.006	Coude 3/4	Elbow, 3/4	Winkel 3/4	Codo 3/4	1
60	050.102.634	Raccord M 3/4 BSP - 3/4 NPS (alimentation en air)	Fitting, M 3/4 BSP - 3/4 NPS (air supply)	Nippel AG 3/4 BSP - 3/4 NPS (Luftversorgung)	Racor M 3/4 BSP - 3/4 NPS (alimentación en aire)	1